



SME1400B-10

Low Cost Broadband Surface Mount Mixer

The Communications Edge™

Product Features

- RF 1 to 2200 MHz
- LO 1 to 2200 MHz
- IF 1 to 2000 MHz
- LO Drive: +10 dBm (Other Levels Available)
- No Internal Solder Connections

Product Photo



Specifications

Parameter	Units	Typical	Guaranteed	
			+25°C	-40° to +85°C
SSB Conversion Loss (Max)				
RF/LO = 10-1300 MHz, IF = 10-1000 MHz	dB	6.2	8.0	8.5
RF/LO = 10-2500 MHz, IF = 10-1000 MHz	dB	7.5	9.0	9.5
RF/LO = 1-2500 MHz, IF = 1-2000 MHz	dB	8.0		
Port-to-Port Isolation (Min)				
L-R = 10-2000 MHz	dB	35		24
L-R = 10-2500 MHz	dB	25		18
L-I = 10-2000 MHz	dB	26		20
L-I = 10-2500 MHz	dB	22		16
R-I	dB	25		
3rd Order Input Intercept Point	dBm	19		
VSWR				
R-Port = 600-2000 MHz		1.7:1		
R-Port = 10-2500 MHz		2.0:1		
L-Port = 600-2000 MHz		1.6:1		
L-Port = 10-2500 MHz		2.0:1		
I-Port		1.8:1		
1 dB Conversion Compression	dBm	+6		

1. Measured in a 50-ohm system with nominal LO drive of +10 dBm, low side LO, and downconverter application only, unless otherwise specified.

2. Measured at LO = 400-2100 MHz, RF = 500-2200 MHz, IF = 100 MHz, unless otherwise specified.

Absolute Maximum Ratings

Parameter	Rating
Operating Temperature	-40 to +85°C
Storage Temperature	-65 to +100°C
RF Input Power	+16 dBm at +25°C

Ordering Information

Part No.	Description
SME1400B-10	Mixer (Available in tape and reel)
SME1400B-10-PCB	Fully Assembled Application Circuit

Performance Charts

IIP3 vs. Frequency

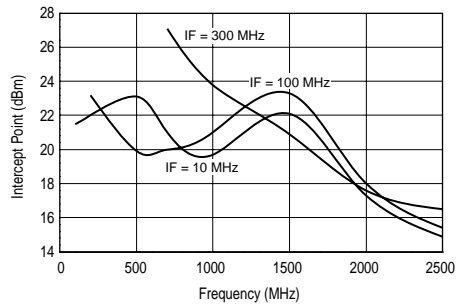

IIP3 vs. LO Power

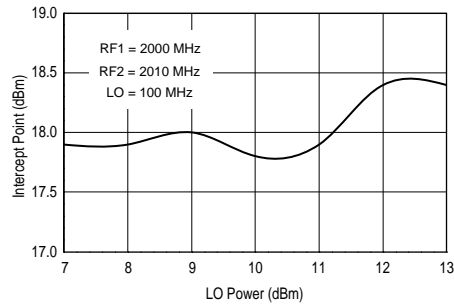

Conversion Loss vs. Frequency

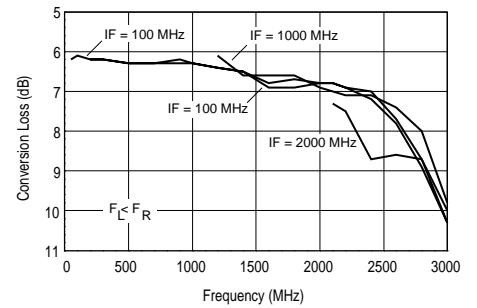

Conversion Loss vs. RF Power

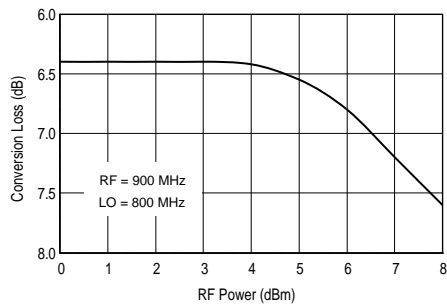

Conversion Loss vs. LO Power

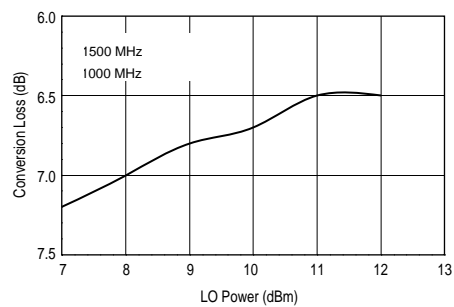

Conversion Loss vs. Temperature

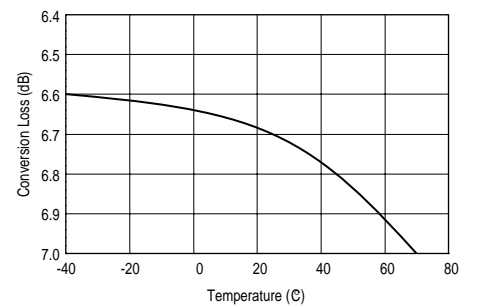

VSWR vs. Frequency

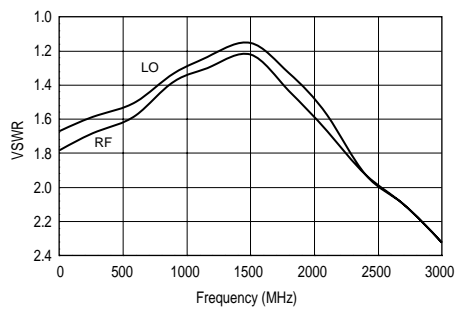

IF VSWR vs. Frequency

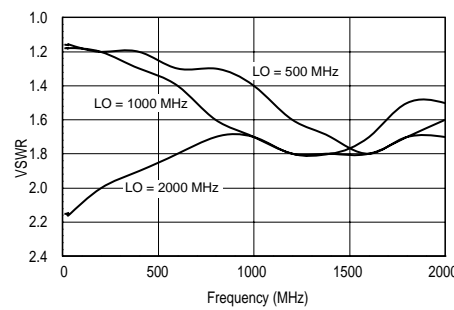

Isolation vs. Frequency

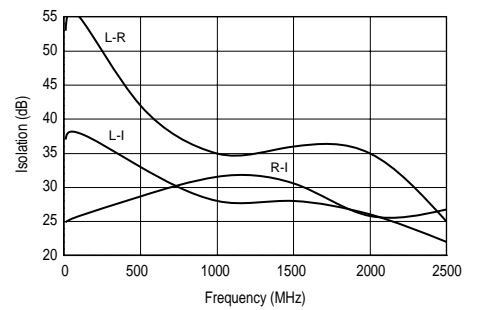

Single-Tone IM Products

		Harmonics of fLO					
		0	1	2	3	4	5
Harmonics of fRF	0		34	44	46	57	53
	1	27	0	33	12	35	28
	2	63	55	56	55	59	59
	3	>80	69	>80	68	73	47
	4	77	>80	>80	>80	>80	>80
	5	>80	>80	>80	>80	>80	>80

LO Mult	RF Mult	LO MHz	RF MHz	IM Prod MHz	dB
0	1	1950	2000	2000	27
0	2	1950	1000	2000	63
0	3	1950	700	2100	84
0	4	1950	600	2400	77
0	5	1950	400	2000	80
1	0	2000	1950	2000	34
-1	1	1950	2000	50	0
1	-2	2000	975	50	55
1	-3	2000	650	50	69
1	-4	2000	488	48	90
1	-5	2000	390	50	88
2	0	1000	1950	2000	44
-2	1	550	2000	900	33
2	-2	2000	1975	50	56
2	-3	2000	1317	49	89
2	-4	2000	988	48	90
2	-5	2000	790	50	89
3	0	700	1950	2100	46
-3	1	400	1550	350	12
3	-2	1500	1200	2100	55
3	-3	2000	1983	51	68
-3	4	2200	1700	200	80
3	-5	2000	1190	50	89
4	0	500	1950	2000	57
-4	1	420	2000	320	35
4	-2	800	1200	800	59
4	-3	1100	1200	800	73
4	-4	2000	1987	52	89
-4	5	2075	1700	200	88
5	0	400	1950	2000	53
-5	1	350	1950	200	28
5	-2	700	1200	1100	59
5	-3	1000	1200	1400	47
5	-4	1150	1200	950	86
5	-5	1710	1700	50	88

Test Conditions RF at -10 dBm; LO at +10 dBm

RF harmonics and intermodulation products are referenced to a desired signal produced by fLO = 2000 MHz and fRF = 1950 MHz.

LO harmonics are referenced to the LO drive signal.

Outline Drawing

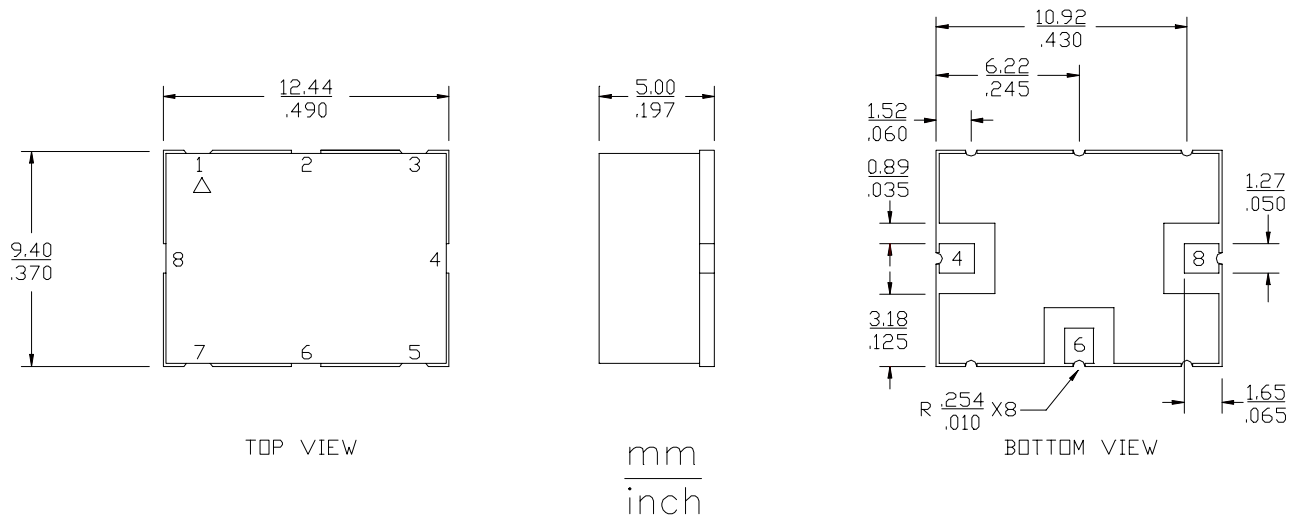

Land Pattern

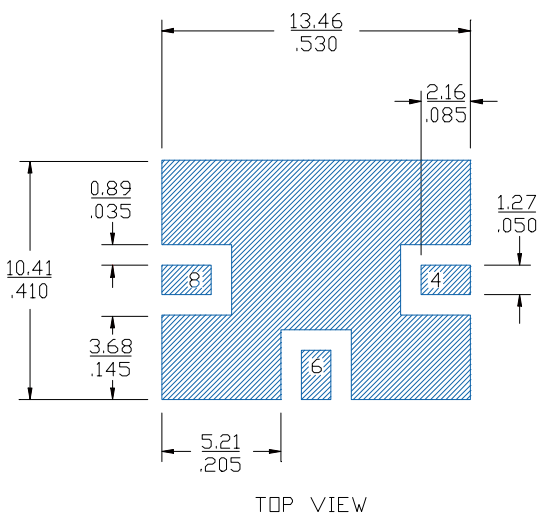

Mounting Configuration

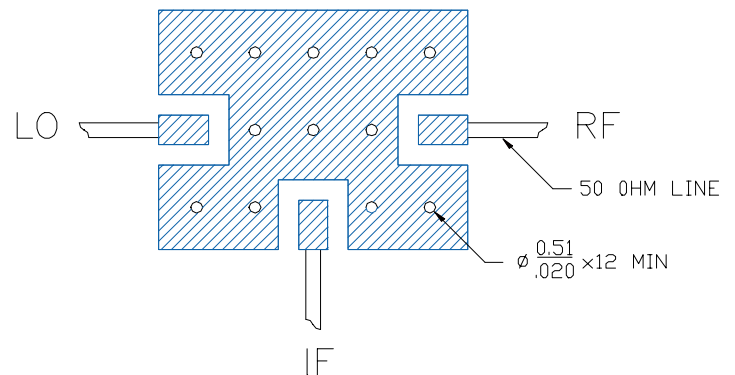

FUNCTION	PIN NO.
GROUND	1-3
RF	4
GROUND	5
IF	6
GROUND	7
LO	8

- Notes:
1. Ground vias are critical for thermal and RF grounding considerations.
 2. A minimum of 12 ground vias are required.
 3. If your PCB design rules allow, ground vias should be placed under the land pattern for better RF and thermal performance. Otherwise ground vias should be placed as close to land pattern as possible.
 4. Trace width depends on PC board.

Specifications and information are subject to change without notice.



Caution! ESD sensitive device.